

electric chain hoist

**DMK**

**series**



 **donati**

# ELECTRIC CHAIN HOIST

DMK series, the most reliable and safe way to lift



The DMK electric chain hoists respond to the needs of the international markets which require products of guaranteed quality with a wide range of uses, long-term reliability, safety guarantees in all phases of operation,

and excellent value for money. The DMK hoists stand out for their careful and modern design putting them at the top of their category. The quality of the components, the high technology used in the production of the mechanical parts, in the finishes and in the surface treatments, the constant and checked quality system UNI EN ISO 9001 which covers the company's entire production, allow DONATI SOLLEVAMENTI to offer a product in line with the latest international standards.

The special water-repellent paintwork is applied with an electrostatic process in complete isolation which guarantees its durability and a constant high performance, also in particularly hostile environments.

The DMK electric chain hoists are part of the lifting products range manufactured by DONATI SOLLEVAMENTI, a leading

company in its field in Italy, and one of the leading companies in the world in the lifting equipment sector. The warranty lasts 3 years from the delivery date.



**DONATI SOLLEVAMENTI S.r.l**

**presents its advanced and innovative electric chain hoists.**

**The DMK hoists are safe, reliable, compact and economical, and represent a modern solution perfectly suited to the needs of the worldwide market for lifting loads up to 4000 kg.**



*electric chain hoist*



*and trolleys*

*power and safety*



*at your disposal*

## **THE ELECTRIC CHAIN HOIST AND TROLLEYS**

The electric chain hoist is a machine generally used to lift an unguided load by means of a hook or handling accessories suitable for the purpose.

The hoist combined with an electric or manual trolley, which run on beam, ensures the integrated handling of lifting and horizontal movements of the load.

The electric chain hoist and the trolleys can be fitted on a beam (monorails) or can constitute the lifting unit of other

machines in which they have been incorporated, such as: jib crane, overhead travelling crane, etc.

The electric chain hoist, positioned on a beam or at ground-level, can be used in different configurations in a fixed position.

The range of DMK electric chain hoists series is produced in:

- **4 basic sizes:** DMK 1 - 2 - 3 - 4, to lift loads from 100 to 4.000 kg, available as standard executions, in the FEM (ISO) service units - 1Bm (M3) 1Am (M4) - 2m (M5).
- **with one lifting speed** made with a 1 polarity motor:
  - 4 or 6,3; 8; 16 m/min for 1 chain fall hoists
  - 2,5 or 3,2; 4 m/min for 2 chain fall hoists
- **with two lifting speeds** made with pole change motor:
  - 4/1, 2 or 8/2,5 m/min for 1 chain fall hoists
  - 2,5/0,8 or 3,2/1 m/min for 2 chain fall hoists
- **standard hook runs:** up to 12 m
  - above 12 m available on request



# ELECTRIC CHAIN HOIST

the range of the DMK series

The flexibility of utilization of DMK hoists allows 6 standard configurations.

**Fixed configuration:** eyebolt suspension as a standard, or hook suspension on request.

**Hand-pushed trolley configuration:** horizontal movement pushing the load. It is recommended for light duty and short load travel only.

**Electrically-operated trolley configuration:** this version is recommended when manual load pushing is not feasible, and for heavy duty. The load is moved by the trolley which is controlled by the hoist pushbutton panel.

**Manual gear operated chain trolley configuration:** the trolley is operated by use of a chain that moves the wheels and is controlled by the operator. This configuration is used in applications accomplishing a low number of cycles, when load travel is short, or when micro inching is required.

**Low headroom execution:** the hoist, to get the maximum hook-run is fitted on a frame with a return system for the chain, the frame is mounted on 2 trolleys (executions available electric or hand push).

**"Climbing" execution:** the "climbing" execution allows the reaching of the installation point with the hook and the related chain, without having to lift the entire weight of the hoist. It is particularly suited to the entertainment industry, that is when frequent installation and dismantling of the hoist at greater heights take place.



The DMK electric chain hoists and related electric trolleys are produced according to the design of modular components which, assembled together in relation to commercial needs, as well as the standard versions available in the warehouse, allow various standardized and special executions to be carried out rapidly and economically.

The basic components, motor and reduction gear, thanks to their extreme compactness are assembled together in coaxial line, to ensure maximum use of the hook run and minimum headroom of the hoist body.

The manufacturer uses the most advanced technology based on production processes of high industrialization and allows the realization, by economies of scale, of totally reliable and technically innovative machines.

A high level of quality is guaranteed and checked by the company quality control system according to standard UNI EN ISO 9001: 1994.

## Protection and insulation of electrical parts:

- Self braking lifting and travelling motors: Protection IP55 - Insulation class "F"
- Limit switch: Minimum protection IP65 - Maximum insulation voltage 500 V
- Cables: CEI 20/22 II - Maximum insulation voltage 450-750 V
- Protections and insulations different from standard are available on request.

## Electrical power supply:

The DMK electric chain hoists are designed to be powered with alternate current with:

- three-phase voltage of 400 V - 50 Hz. according to IEC 38-1.
- single-phase voltage of 230 V +/- 5% - 50 Hz. (for DMK hoists 1 - 2 - 3, at one speed and capacity up to 800 kg).
- Voltage and frequency different from standard are available on request.

## Nominal conditions of use in standard execution:

- Temperature of use: minimum - 10° C; maximum +40° C.
- Maximum relative humidity: 80%
- Maximum altitude 1000 m above sea level.
- The machine must be placed indoors, in a well-ventilated place free of corrosive vapours (acid vapours, saline mist, etc).
- Special executions, for different environmental conditions or for outdoor use are available on request.

## Noise

- The level of acoustic pressure emitted by the hoist at full load is always less than a level of 85dB (A). The incidence of environmental characteristics such as sound transmission from the ground through metallic structures, reflections caused by combined machines and walls is not included in the level indicated.



# THE HOIST IN DETAILS

## 1. Reduction gear

Epicyclic crown wheel with heat-treated high-strength steel gearing supported by oil-bath lubricated ball bearings. Noise level at full load is less than 85 db. The aluminium casing is finned externally for more effective heat dissipation by radiation.

## 2. Self-braking electrical motor

The axial movement of the tapered brake ensures a fast braking action that remains reliable upon time accrual [RES. 4.1.2.1 c - Machinery Directive].  
Brake lining is asbestos-free. The motor is available in two versions: a single polarity version for one-speed hoists, and a pole change version for two-speed hoists.

## 3. Chain

The chain is gauged and made of high-strength steel rod having an ultimate tensile strength of 80 kg/mm<sup>2</sup>, and ultimate elongation higher than 10%.  
The applicable safety coefficient is always better than 5 [RES. 4.1.2.4 - Machinery Directive].  
The heat and galvanising treatments applied to the chain ensure high resistance to wear, aging and corrosion.

## 4. Load sprocket

The load sprocket is heat treated, and has five pockets. The pockets are machined by use of precision machinery. The sprocket drives the chain, and ensures optimized chain motion.

## 5. Chain guide (inserter/extractor)

This component provides for insertion and extraction of the chain links into and from the pockets of the load sprocket, both in ascent and descent. [RES. 4.1.2.6 - Machinery Directive].

## 6. Load hook

The hook, made of high strength forged steel, is fitted with a safety device [RES. 4.1.2.6 - Machinery Directive], and rotates on a thrust bearing.

## 7. Single fall bottom block (1 chain fall hoists)

The bottom block is the joining element between the chain and the hook. It is made of steel, and is equipped with a heat-treated large cross-section chain locking pin.

## 8. Two falls hookblock (2 chain fall hoists)

Made of aluminium, completely closed, it is equipped with a high-resistance steel transmission reel, thermally treated, with pockets for the housing of the chain.

## 9. Chain stops

The stops are fitted on both the ascending and descending sections of the chain. They act as limit switches of hook travel [RES. 4.1.2.6 a - Machinery Directive], and can be set as desired. They are made of forged steel, and are fitted with a shock-absorbing insert.

## Chain box

The chain box is available in several sizes as a function of hook travel. It is made of shock-resistant plastics and is fitted with suspensions which ensure freedom of movement.

## 10. Clutch device

The clutch is an emergency device that replaces the traditional electrical limit switches as chain full up and down stops. It also operates as an overload protection [RES. 4.2.1.4 - Machinery Directive].  
The clutch discs are asbestos-free, and are pre-loaded through a set of Belleville washers.

## 11. Balancer

The balancer is connected to the clutch joint, and provides for correct hoist balancing. It absorbs the heat generated during clutch operation.

## 12. New brake DMK 2-3-4

The new brake shoe fitted in hoist sizes 2-3 and 4 is manufactured with a fan for more efficient cooling of the brake and motor.  
The high degree of inclination of the brake surface allows for optimal braking in the most arduous working conditions.  
Brake movement is simply carried out by the adjustment of the external brake ring.

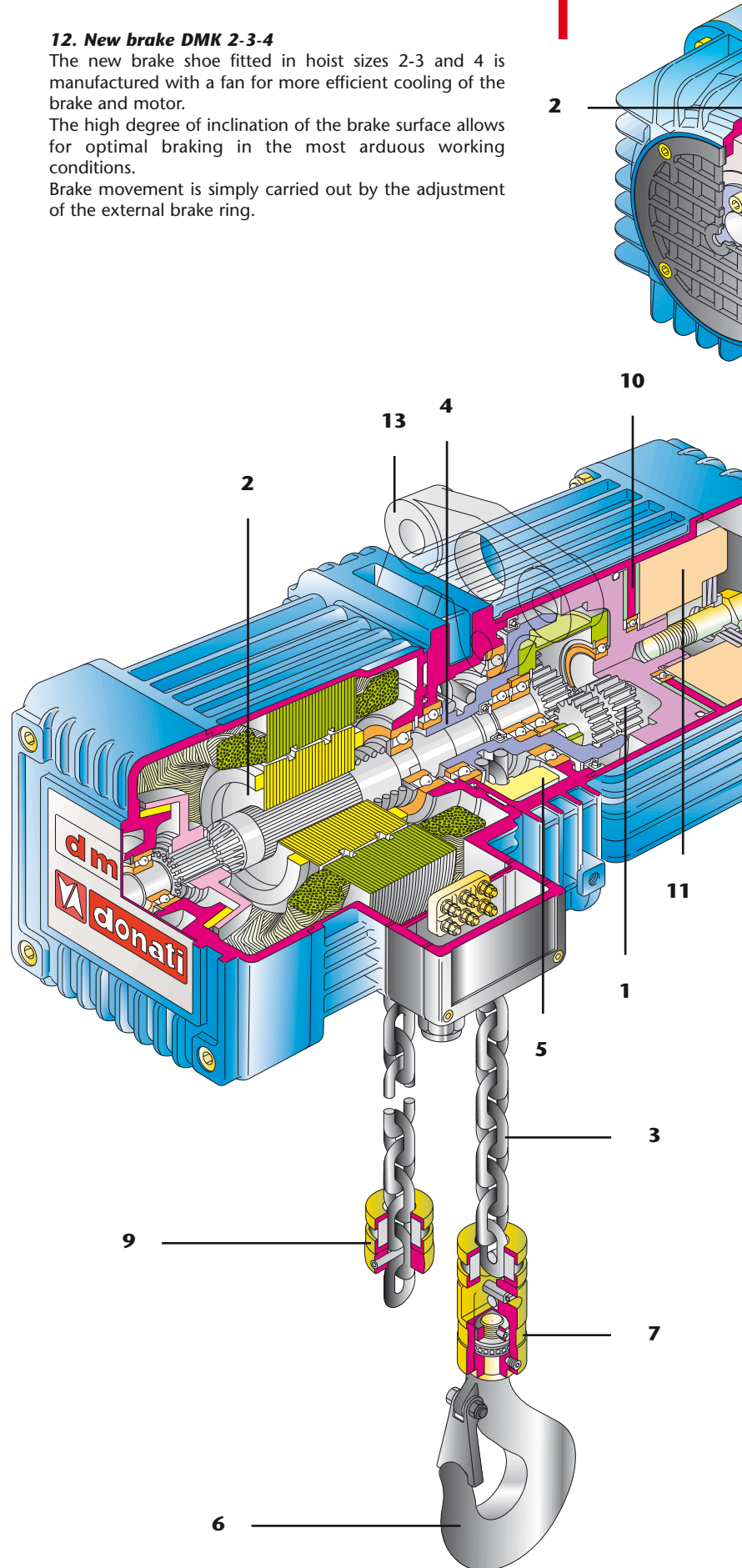

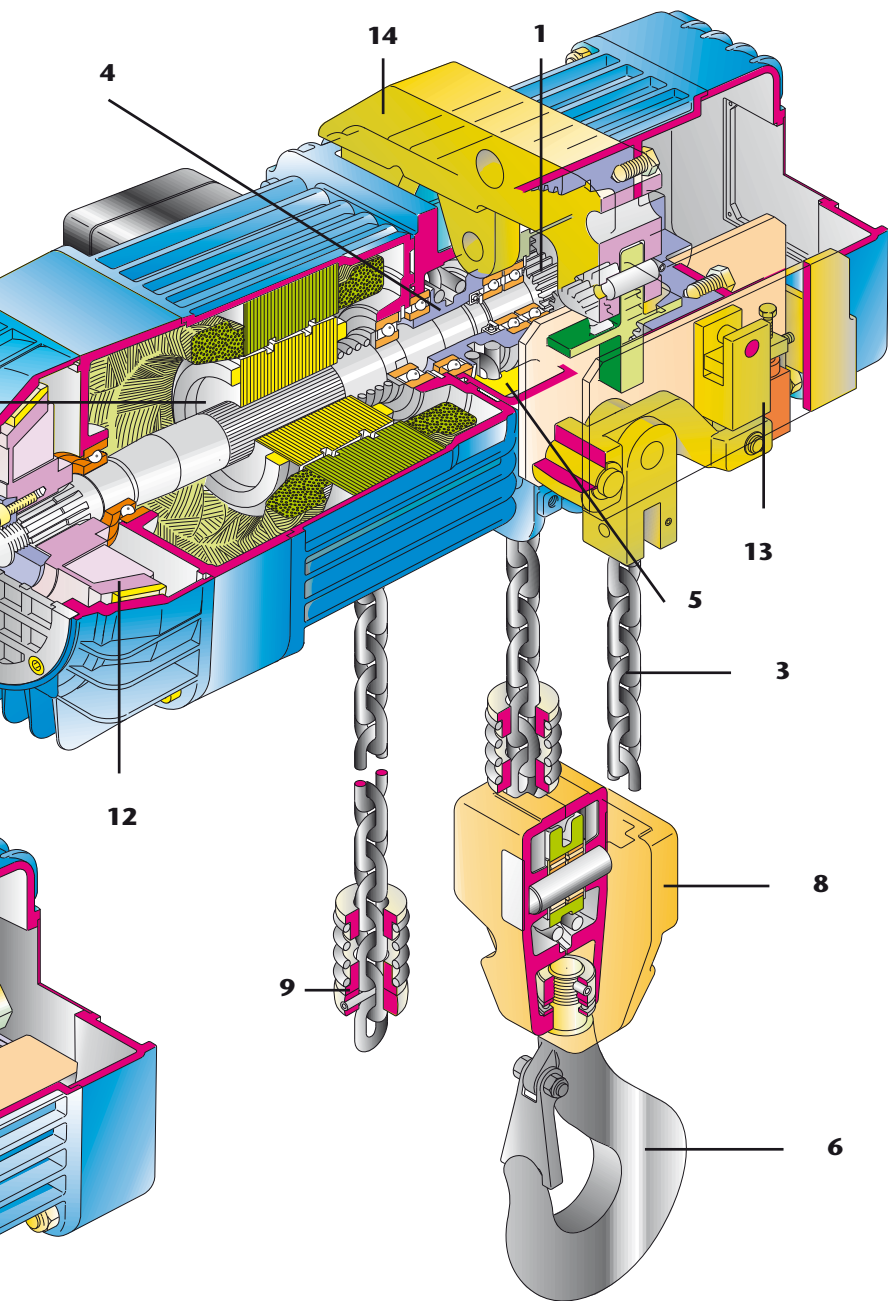

### 1 chain fall up to 2000 kg

A technical innovative solution which provides:

- reduced headroom and a bigger hook-run as the single fall hookblock is of smaller dimensions than a two falls one, the chain collector is also smaller
- greater safety for the operator who can touch the hook and the chain without danger of being dragged along or crushed
- greater reliability, reduced maintenance and lower working costs because the chain cannot jam, there is not wear by the return and in the lower block there are no moving parts to replace
- greater flexibility of use

### 2 chain falls up to 4000 kg

A cost-effective solution in terms of the whole system which:

- offers a fixed anchorage point to which an overload device is fixed suited for heavy applications thereby avoiding the need to over dimension the structures of support
- keep the headroom of the hoist and the cost of the chain low.

### 13. Overload device (2 chain fall hoists)

Electromechanical, with a microswitch for one intervention threshold [RES. 4.2.1.4 - Enclosure 1 Machinery Directive].

The overload device does not permit the hoist to be loaded with an overload exceeding 20% of its maximum capacity, by blocking the control circuit of the lifting control device.

### Lifting limit switches

Included in the supply for the 2 chain fall hoists and available, on request, for 1 chain fall hoists, they limit the hook's ascent and descent run [RES. 4.1.2.6 a) - Enclosure 1 Machinery Directive]. They are made of two precision microswitches which function according to the principle of "slow positive opening" and work on the auxiliary circuit of the control device of the lifting motor.

### 14. Suspension

It is produced with an eyebolt suspension; are available on request, the executions with hook suspension or by eyebolt 90° version for longitudinal positioning of the hoist.

### Electrical controls

When the hoist is supplied with electrical controls, the movements can be activated, alternatively, by:

- **low voltage controls at AC 48 V – 50 Hz**, including: the transformer for the low voltage power supply of the control circuits, the general line contactor, the contactors for the control of the hoist and trolley motors, the protection fuses of the transformer, the terminal block for the connections of the auxiliary and power circuits.

The components are fitted in a box with IP55 protection, made of shockproof thermoplastic material.

The equipment is located on the motor side of the hoist.

- **direct control**, directly connected to the power supply, available exclusively for the control of the electric hoist only, raise/lower functions.

It works by means of a power pushbutton panel which interrupts and directly connects the power line.

In both options, the controls are activated by the pushbutton panel, of ergonomic shape, made of self-extinguishing shockproof thermoplastic material, waterproof with IP65 protection.

The emergency stop function [RES. 1.2.4 - Enclosure 1 Machinery Directive], is produced with a mushroom-head button which using an intentional release action puts the control circuit in the forward position [RES. 1.2.3 - Enclosure 1 Machinery Directive].

The pushbutton panel is connected to the hoist by a multipolar electrical cable supported by tear proof metallic parts.

**DMT trolleys** The trolleys are used when loads are to be moved horizontally. They are identified with code DMT, and are available in the following versions:

- **type SM, hand-pushed**
- **type CM, mechanically-operated chain**
- **type EM, electrically-operated**

They run on the lower flange of the beam and are adjustable for flange width. They are made of pressed steel fitted with stirrups to prevent drop or derailling [RES. 4.1.2.2 - Machinery Directive], and equipped with shock absorbing buffers. The trolleys are fitted with pressed steel machined wheels rotating on permanently lubricated ball bearings.

**Limit switches** These switches limit the horizontal travel of the electrically-operated trolley on the beam [RES. 4.1.2.6 a - Machinery Directive].

**Towing arm** The towing arm, which is the connecting element between the trolley and the power supply is available for all types of trolleys of the DMT series.

It is adjustable in all directions and provides for power supply cable towing as needed to ensure that the cable is not torn.

# design and manufacture

## RULES AND CERTIFICATION



DMK electric chain hoists and trolleys are designed and produced following the "Essential Safety Requirements" of Enclosure I of the Community Directive 98/37/EC ex 89/392/EEC and successive amendments 91/368/EEC, 93/44/EEC and 93/68/EEC, denominated Machinery Directive, transposed into Italian legislation with DPR N° 459 of 24.07.96.

Regarding what was stated in Enclosure II of the Directive 98/37/EC, the hoist can be put on the market in the following ways:

- Complete**, or capable of functioning independently, **having the CE Marque and the EC Declaration of Conformity - Enclosure II A.**
- Incomplete** as destined to be incorporated in another machine and/or to be completed by the Customer. In this case, in accordance with **Article 4 - paragraph 2** of the **Directive 98/37/EC**, the hoist does not carry **the CE Marque** and is supplied with the **Declaration of the Manufacturer - Enclosure II B.**

Furthermore DMK hoists and related trolleys conform to the following Directives:

- **The Low Voltage Directive** (in Italian Direttiva Bassa Tensione DBT) **73/23/EEC**, transposed into Italian legislation with **Law No 791/77** modified with **D.Lgs No 626/96** and with **D.Lgs. No 277/97.**
- **The Electromagnetic Compatibility Directive (EMC) 89/336/EEC** transposed into Italian legislation with **D.Lgs. No 476/92** modified with **D.Lgs. N° 615/96.**

DMK electric chain hoists and trolleys are available, on request, with homologation CSA with **ANSI/UL** extension.

### Reference frame

The design and manufacture of DMK electric chain hoists conform to the following rules and technical regulations:

- EN 12077 - 2: "Cranes safety. Requirements for health and safety - Limiting and indicating devices".
- EN 12100 parts: 1a - 2a "Safety of the machinery".

- EN 60204 - 1: "Safety of the electrical equipment of the machines - General rules".
- EN 60204 - 32: "Safety of the electrical equipment of lifting machines".
- EN 60439 - 1: "Low voltage controls equipment".
- EN 60529: "IP enclosure".
- ISO 4301: "Classification of lifting equipment".
- DIN 15401: "Choice of the lifting hooks".

- FEM 9.511/86 "Mechanisms classification"
- FEM 9.671/88 "Quality of chains, criteria of choice and technical requirements"
- FEM 9.683/95: "Choice of the lifting and traverse motors".
- FEM 9.755/93: "Periods of safe work".
- FEM 9.941/95: "Control symbols".

## Criteria of use and operating limits

- It is necessary to check the parameters which characterize operating limits of the DMK electric chain hoists to be able to have a complete correspondance between the DMK electric chain hoists and the service they were designed for. The operating limits are: **actual lifting capacity**, **state of stress** and **average duration of daily use**.

### 1) Actual lifting capacity

- This is determined by the heaviest load to be lifted.

*The nominal lifting capacity of the hoist must be  $\geq$  the actual lifting capacity*

*Lifting capacity = kg*

### 2) State of stress

- The state of stress is evaluated considering the actual entity of the loads to be lifted and it is ascribable to one of the four spectrums of load shown below which determine the type of service.

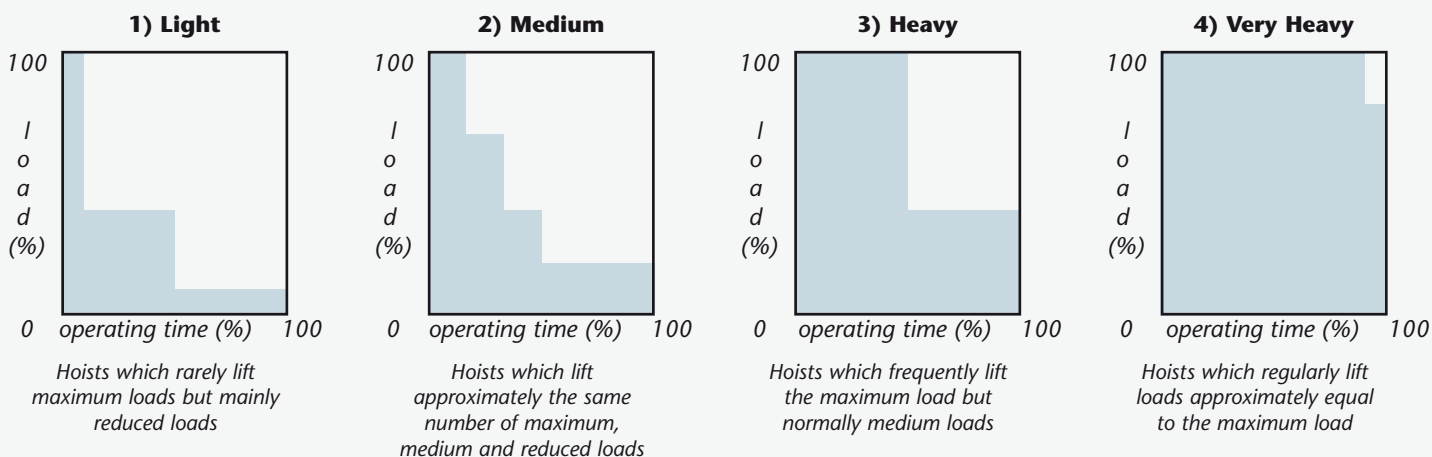

### 3) Average duration of daily use - Tm = Hours

- For **lifting** operations the average duration of use is decided in the following way:

$$T_m \text{ (hours)} = \frac{AHR \times C/h \times Rt}{30 \times S}$$

**Actual hook run**

**AHR = m**

*It is the average of the actual runs of the load*

**Operative cycles**

**C/h = N° cycles per hour**

*It is the number of complete ascents and descents carried out in an hour*

**Running time**

**Rt = hours**

*Hoist running time in a whole day*

**Lifting speed**

**S = m/min.**

*It is the distance covered by the load in a minute*

Check that the **State of stress** and the **average duration of daily use** verified are not in contrast with the data in the following table; and, according to the capacity, choose the hoist.

Operating limits of DMK hoists in relation with the service groups of the mecahnisms, according to FEM 9.511/86 (ISO 4301/88)							
FEM (ISO) Group	Average duration of daily use - Tm=Hours; with load				Intermittance rapport %	N of starts per hour	N of cycles per hour
	1) Light	2) Medium	3) Heavy	4) Very heavy			
<b>1 Bm</b> (M 3)	≤ 2	≤ 1	≤ 0.5	≤ 0.25	RI = 25%	S/h = 150	C/h = 25
<b>1 Am</b> (M 4)	≤ 4	≤ 2	≤ 1	≤ 0.5	RI = 30%	S/h = 180	C/h = 30
<b>2 m</b> (M 5)	≤ 8	≤ 4	≤ 2	≤ 1	RI = 40%	S/h = 240	C/h = 40

## Characteristics and technical data for DMK chain hoists and DMT trolleys

Characteristics and technical data for DMK chain hoists and DMT trolleys																			
Capacity (kg)	FEM Group	Type DMK	Chain falls	Lifting speed (m/min.)		Lifting motor power (KW)		DMT trolley for hoist and related speed (m/min.) E=electric trolley S=manual-push trolley C=manual gear operated trolley						Trolley motor power (KW) Speed (m/min.)				Chain type	weight of 1 meter of chain (kg/m)
				1 Speed	2 Speed	1 Speed	2 Speed	S	C	11	14	22	7 22	11	14	22	7 22		
125	2m	154C	1	8	/	0.2	/	SM2	CM3	EM3	EM3	EM3	EM3	0.12	0.18	0.25	0.08 0.25	4x12	0.38
	2m	132D	1	8	2.5	0.2	0.06	SM2	CM3	EM3	EM3	EM3	EM3	0.12	0.18	0.25	0.08 0.25	4x12	0.38
	2m	232C	1	16	/	0.4	/	SM2	CM3	EM3	EM3	EM3	EM3	0.12	0.18	0.25	0.08 0.25	5x15	0.58
250	2m	134C	1	4	/	0.2	/	SM2	CM3	EM3	EM3	EM3	EM3	0.12	0.18	0.25	0.08 0.25	4x12	0.38
	2m	112D	1	4	1.2	0.2	0.06	SM2	CM3	EM3	EM3	EM3	EM3	0.12	0.18	0.25	0.08 0.25	4x12	0.38
	2m	234C	1	8	/	0.4	/	SM2	CM3	EM3	EM3	EM3	EM3	0.12	0.18	0.25	0.08 0.25	5x15	0.58
	2m	234D	1	8	2.5	0.4	0.12	SM2	CM3	EM3	EM3	EM3	EM3	0.12	0.18	0.25	0.08 0.25	5x15	0.58
	2m	332C	1	16	/	0.8	/	SM3	CM3	EM3	EM3	EM3	EM3	0.12	0.18	0.25	0.08 0.25	7x21	1.16
500	2m	214C	1	4	/	0.4	/	SM2	CM3	EM3	EM3	EM3	EM3	0.12	0.18	0.25	0.08 0.25	5x15	0.58
	2m	214D	1	4	1.2	0.4	0.12	SM2	CM3	EM3	EM3	EM3	EM3	0.12	0.18	0.25	0.08 0.25	5x15	0.58
	2m	334C	1	8	/	0.8	/	SM3	CM3	EM3	EM3	EM3	EM3	0.12	0.18	0.25	0.08 0.25	7x21	1.16
	2m	334D	1	8	2.5	0.8	0.24	SM3	CM3	EM3	EM3	EM3	EM3	0.12	0.18	0.25	0.08 0.25	7x21	1.16
	2m	432C	1	16	/	1.6	/	SM4	CM4	EM4	EM4	EM4	EM4	0.12	0.18	0.25	0.08 0.25	10x28	2.42
1000	2m	314C	1	4	/	0.8	/	SM3	CM3	EM3	EM3	EM3	EM3	0.12	0.18	0.25	0.08 0.25	7x21	1.16
	2m	314D	1	4	1.2	0.8	0.24	SM3	CM3	EM3	EM3	EM3	EM3	0.12	0.18	0.25	0.08 0.25	7x21	1.16
	2m	434C	1	8	/	1.6	/	SM4	CM4	EM4	EM4	EM4	EM4	0.12	0.18	0.25	0.08 0.25	10x28	2.42
	2m	434D	1	8	2.5	1.6	0.5	SM4	CM4	EM4	EM4	EM4	EM4	0.12	0.18	0.25	0.08 0.25	10x28	2.42
1600	2m	424L	1	6.3	/	2.5	/	SM4	CM4	EM4	EM4	EM4	EM4	0.12	0.18	0.25	0.08 0.25	10x28	2.42
	1Am	424D	1	6.3	2.1	2	0.65	SM4	CM4	EM4	EM4	EM4	EM4	0.12	0.18	0.25	0.08 0.25	10x28	2.42
2000	2m	414C	1	4	/	1.6	/	SM4	CM4	EM4	EM4	EM4	EM4	0.12	0.18	0.25	0.08 0.25	10x28	2.42
	2m	414D	1	4	1.2	1.6	0.5	SM4	CM4	EM4	EM4	EM4	EM4	0.12	0.18	0.25	0.08 0.25	10x28	2.42
2500	2m	434L.I	2	4	/	2.5	/	SM5	CM5	EM5	EM5	EM5	EM5	0.17	0.25	0.37	0.08 0.25	10x28	2.42
	2m	424D.I	2	3.2	1	2	0.65	SM5	CM5	EM5	EM5	EM5	EM5	0.17	0.25	0.37	0.08 0.25	10x28	2.42
3200	1Am	434L.J	2	4	/	2.5	/	SM5	CM5	EM5	EM5	EM5	EM5	0.17	0.25	0.37	0.08 0.25	10x28	2.42
	1Am	424D.J	2	3.2	1	2	0.65	SM5	CM5	EM5	EM5	EM5	EM5	0.17	0.25	0.37	0.08 0.25	10x28	2.42
	2m	424L.J	2	3.2	/	2.5	/	SM5	CM5	EM5	EM5	EM5	EM5	0.17	0.25	0.37	0.08 0.25	10x28	2.42
	2m	454D.J	2	2.5	0.8	2	0.65	SM5	CM5	EM5	EM5	EM5	EM5	0.17	0.25	0.37	0.08 0.25	10x28	2.42
4000	1Am	424L.K	2	3.2	/	2.5	/	SM5	CM5	EM5	EM5	EM5	EM5	0.17	0.25	0.37	0.08 0.25	10x28	2.42
	1Am	454D.K	2	2.5	0.8	2	0.65	SM5	CM5	EM5	EM5	EM5	EM5	0.17	0.25	0.37	0.08 0.25	10x28	2.42

### Single-phase DMK chain hoists

Capacity (kg)	FEM Group	Type DMK	Chain falls	Lifting speed (m/min.)		Lifting motor power (KW)		DMT trolley for hoist and related speed (m/min.) E=electric trolley S=manual-push trolley C=manual gear operated trolley						Trolley motor power (KW) Speed (m/min.)				Chain type	weight of 1 meter of chain (kg/m)
				1 Speed	2 Speed	1 Speed	2 Speed	S	C	11	14	22	7 22	11	14	22	7 22		
100	1Bm	132M	1	8	/	0.2	/	SM2	CM3	EM3	/	/	/	0.1	/	/	/	4x12	0.38
200	1Bm	112M	1	4	/	0.2	/	SM2	CM3	EM3	/	/	/	0.1	/	/	/	4x12	0.38
	1Bm	234M	1	8	/	0.4	/	SM2	CM3	EM3	/	/	/	0.1	/	/	/	5x15	0.58
400	1Bm	214M	1	4	/	0.4	/	SM2	CM3	EM3	/	/	/	0.1	/	/	/	5x15	0.58
	1Bm	334M	1	8	/	0.8	/	SM3	CM3	EM3	/	/	/	0.1	/	/	/	7x21	1.16
800	1Bm	314M	1	4	/	0.8	/	SM3	CM3	EM3	/	/	/	0.1	/	/	/	7x21	1.16

**DMK electric chain hoists - overall dimensions - weights - Eye suspension**

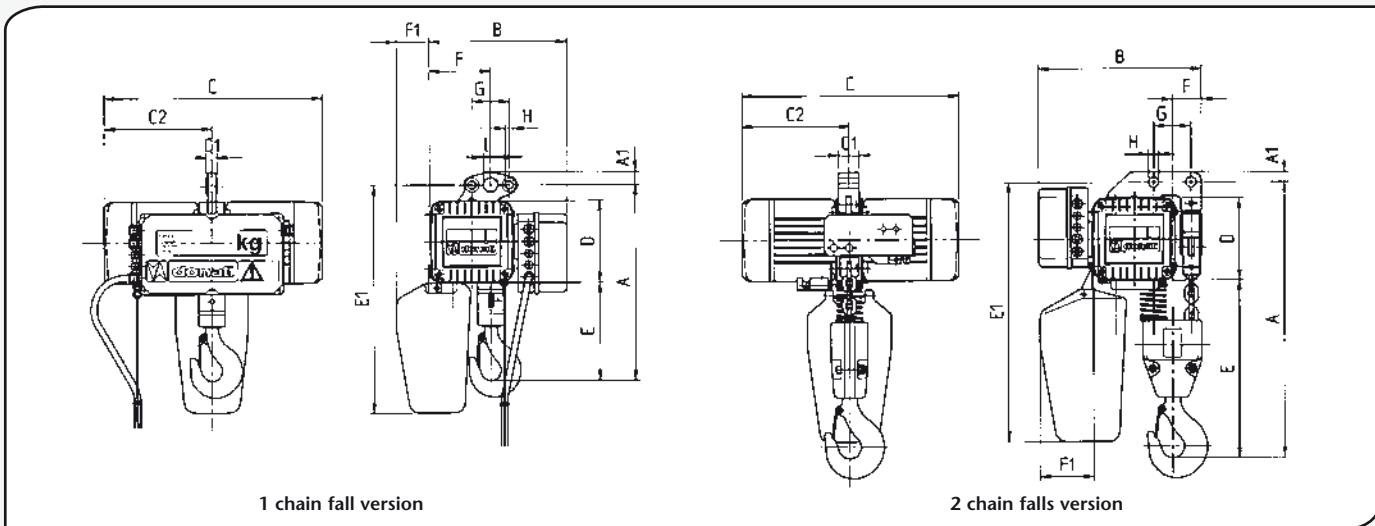

Size	Chain falls	Type DMK	*Hoist weight (kg)	Overall dimensions (mm)											
				**A	A1	B	C	C1	C2	D	**E	F	G	H	I
1	1	154C	23	285	23	253	355	19	177	120	138	80	70	14	27
	1	132D/M	23	285	23	253	355	19	177	120	138	80	70	14	27
	1	134C	23	285	23	253	355	19	177	120	138	80	70	14	27
	1	112D/M	23	285	23	253	355	19	177	120	138	80	70	14	27
2	1	232C	33	320	23	268	438	19	237	135	160	92	70	14	27
	1	234C/M	33	320	23	268	438	19	237	135	160	92	70	14	27
	1	234D	33	320	23	268	438	19	237	135	160	92	70	14	27
	1	214C/M	33	320	23	268	438	19	237	135	160	92	70	14	27
3	1	314D	33	320	23	268	438	19	237	135	160	92	70	14	27
	1	332C	50	392	28	293	514	25	274	160	202	114	70	14	30
	1	334C/M	50	392	28	293	514	25	274	160	202	114	70	14	30
	1	334D	50	392	28	293	514	25	274	160	202	114	70	14	30
4	1	314C/M	50	392	28	293	514	25	274	160	202	114	70	14	30
	1	432C	80	483	32	332	583	27	317	200	245	146	90	20	35
	1	434C	80	483	32	332	583	27	317	200	245	146	90	20	35
	1	434D	80	483	32	332	583	27	317	200	245	146	90	20	35
	1	424L	80	483	32	332	583	27	317	200	245	146	90	20	35
	1	414C	80	483	32	332	583	27	317	200	245	146	90	20	35
	1	414D	80	483	32	332	583	27	317	200	245	146	90	20	35
	2	434L.I	105	670	25	395	583	50	317	200	432	71	90	25	/
	2	424D.I	105	670	25	395	583	50	317	200	432	71	90	25	/
	2	434L.J	105	670	25	395	583	50	317	200	432	71	90	25	/
	2	424D.J	105	670	25	395	583	50	317	200	432	71	90	25	/
	4	2	454D.J	105	670	25	395	583	50	317	200	432	71	90	25
2		424L.K	105	670	25	395	583	50	317	200	432	71	90	25	/
2		454D.K	105	670	25	395	583	50	317	200	432	71	90	25	/
2		454D.K	105	670	25	395	583	50	317	200	432	71	90	25	/

\* Weight of hoist with 3m hook run and 2m pushbutton panel cable.

\*\* With application of raise/lower electric limit switches A and E dimensions increase by: DMK 1 + 45 mm  
 DMK 2 + 40 mm  
 DMK 3 + 45 mm  
 DMK 4 (1 fall) + 60 mm

**Chain box type (C-D-E-F-G-H-I)**

Size	Chain falls		C	D	E	F	G	H	I
1	1	Max hook run (m)	5	8	12	20	32	70	115
	1	E1	347	372	397	427	467	522	607
	1	F1	47	63	77	100	120	150	200
2	1	Max hook run (m)	/	4	7	12	18	24	85
	1	E1	/	385	410	440	480	535	620
	1	F1	/	56	70	92	112	142	122
3	1	Max hook run (m)	/	/	3	5	10	12	24
	1	E1	/	/	440	470	510	560	650
	1	F1	/	/	55	77	97	127	177
4	1	Max hook run (m)	/	/	/	/	4	8	16
	1	E1	/	/	/	/	560	610	700
	1	F1	/	/	/	/	80	110	160
	2	Max hook run (m)	/	/	/	/	/	3	5
	2	E1	/	/	/	/	/	628	718
4	2	F1	/	/	/	/	130	180	

NOTE With application of raise/lower limit switches on 1 chain fall hoists, the maximum capacity of the chain box decreases by 1 m of hook run and the E1 dimension increases by 25 mm.

# DMK electric chain hoists with DMT travel trolleys

## Overall dimensions - Weights

Hoist with SM hand-push trolley

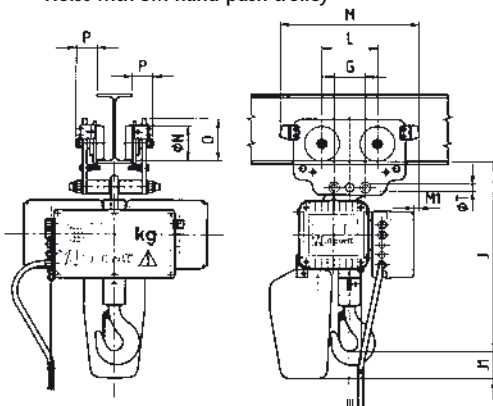

Hoist with CM manual gear operated trolley J1 = (E1-A)

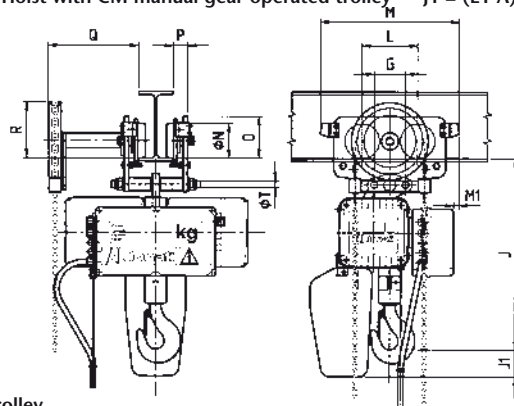

Hoist with EM electric trolley

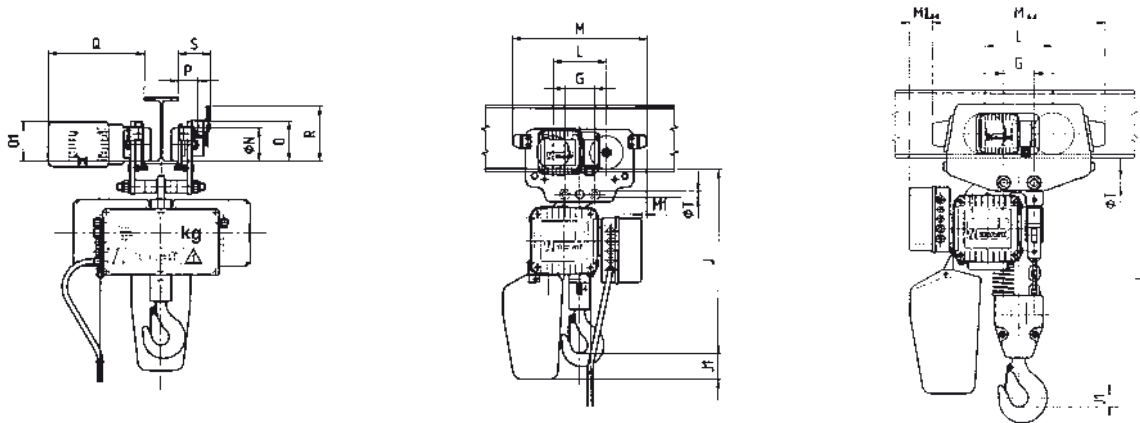

DMK size	Chain falls	DMT trolley type	*Hoist trolley weight (kg)	Overall dimensions (mm)											
				***J	L	M	M1	ØN	O	**O1	P	**Q	R	S	ØT
1	1	SM2	29	340	100	236	54	52	72	/	20	/	/	/	M16
	1	EM3	58	355	135	362	-10	80	98	100(108)	54	260(280)	165	90	M14
	1	CM3	41	355	135	362	-10	80	98	/	54	240	108	/	M14
2	1	SM2	39	375	100	236	58	52	72	/	20	/	/	/	M16
	1	EM3	68	390	135	362	-6	80	98	100(108)	54	260(280)	165	90	M14
	1	CM3	51	390	135	362	-6	80	98	/	54	240	108	/	M14
3	1	SM3	62	456	135	362	-3	80	98	/	54	/	/	/	M14
	1	EM3	85	456	135	362	-3	80	98	100(108)	54	260(280)	165	90	M14
	1	CM3	68	456	135	362	-3	80	98	/	54	240	108	/	M14
4	1	SM4	105	560	160	402	-15	100	120	/	60	/	/	/	M20
	1	EM4	130	560	160	402	-15	100	120	110(118)	60	266(286)	165	96	M20
	1	CM4	115	560	160	402	-15	100	120	/	60	264	160	/	M20
	2	SM5	160	755	201	510	70	125	155	/	55	/	/	/	M24
	2	EM5	190	755	201	510	70	125	155	130(130)	55	295(295)	208	110	M24
	2	CM5	170	755	201	510	70	125	155	/	55	350	198	/	M24

\* Weight referred to 3m- hook-run hoist.

\*\* Dimensions for 2-speed trolley in brackets.

\*\*\* SM3/EM3/CM3: for width > of 220 mm up to 400 mm dimension J increases by 70 mm

SM4/EM4/CM4: for width > of 220 mm up to 400 mm dimension J increases by 60 mm

SM5/EM5/CM5: for width > of 220 mm up to 400 mm dimension J increases by 75 mm

**NOTE** When the hoist is equipped with raise/lower limit switches, dimension J increases as much as dimensions A and E, page 11 and note regarding the chain box.

## Maximum reactions of DMT trolleys wheel on beam flange

DMK size	Max capacity (kg)	DMT trolley type	Overall dimensions (mm)				*max R (kg)
			Ør	i	b		
1	250	SM2	52	5	15	80	
		EM3/CM3	80	7	16	87	
2	500	SM2	52	5	15	154	
		EM3/CM3	80	7	16	161	
3	1000	SM3 EM3/CM3	80	7	16	309	
4	2000	SM4 EM4/CM4	100	9	19	608	
	4000	SM5 EM5/CM5	125	14	29	1193	

\*Max R calculated with a dynamic coefficient of 1.15 and no M increasing coefficient.

## DMK electric chain hoists with DMT trolley low headroom execution

Overall dimensions - Weights

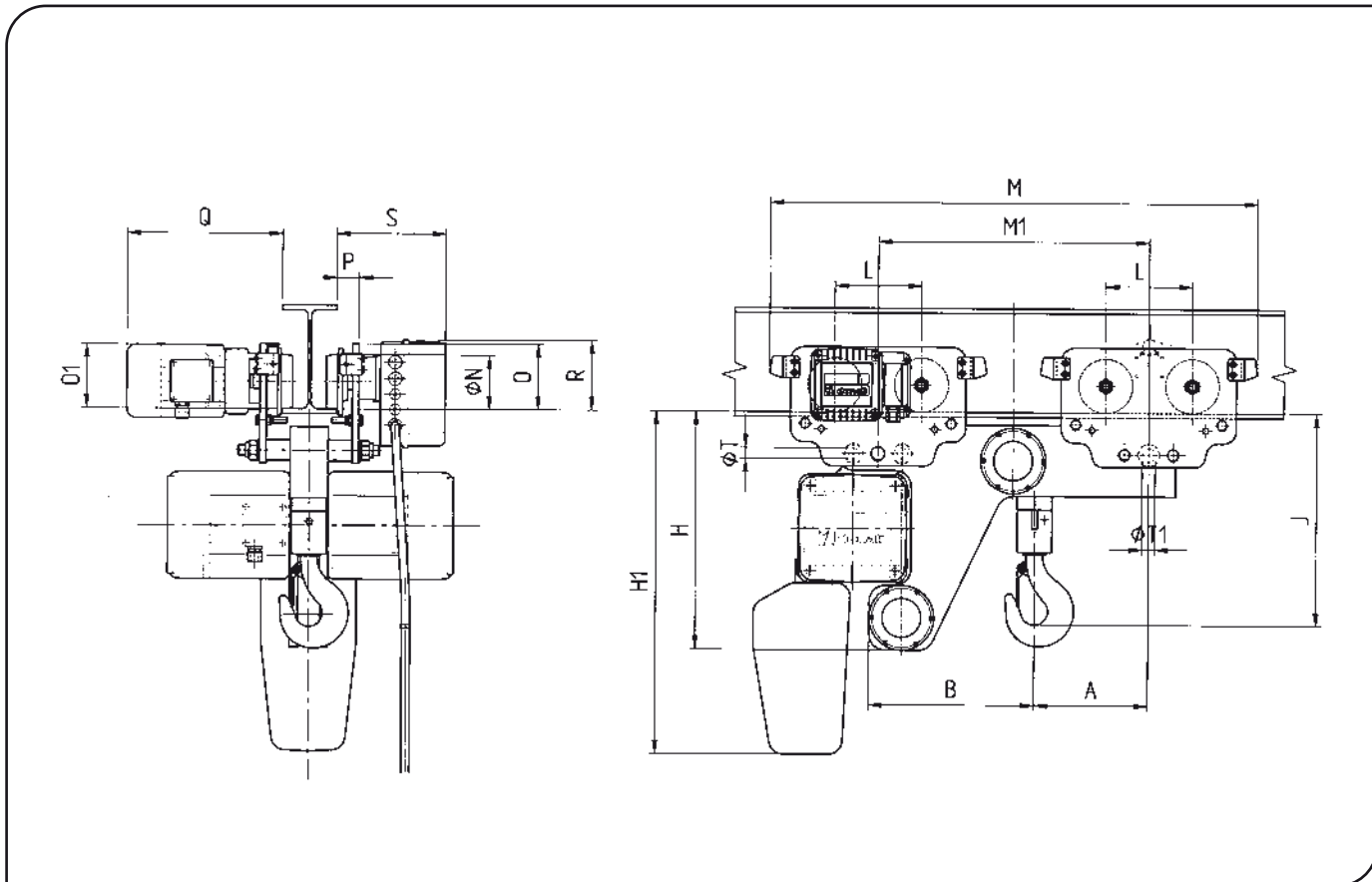

DMK size	Capacity max (kg)	DMT trolley type	*Hoist trolley weight (kg)	Overall dimensions (mm)																
				A	B	H	***H1	J	L	M	M1	ØN	O	**Ø1	P	**Q	R	S	ØT	ØT1
1	250	SM3+SM3	60	170	228	295	417	240	135	742	380	80	98	/	54	/	108	/	M14	M16
		SM3+EM3	75	170	228	295	417	240	135	742	380	80	98	100(108)	54	260(280)	108	160	M14	M16
2	500	SM3+SM3	67	176	240	315	455	265	135	762	400	80	98	/	54	/	108	/	M14	M16
		SM3+EM3	80	176	240	315	455	265	135	762	400	80	98	100(108)	54	260(280)	108	160	M14	M16
3	1000	SM3+SM3	100	190	275	365	510	327	135	812	450	80	98	/	54	/	108	/	M14	M16
		SM3+EM3	115	190	275	365	510	327	135	812	450	80	98	100(108)	54	260(280)	108	160	M14	M16
4	2000	SM4+SM4	155	205	310	440	637	400	160	902	500	100	120	/	60	/	118	/	M20	M24
		SM4+EM4	170	205	310	440	637	400	160	902	500	100	120	110(118)	60	266(286)	118	170	M20	M24
	on request	/	/	/	/	/	/	/	/	/	/	/	/	/	/	/	/	/	/	/
	4000	on request	/	/	/	/	/	/	/	/	/	/	/	/	/	/	/	/	/	/

\* Weight refers to 3m- hook-run hoist.

\*\* Dimensions for 2-speed trolley in brackets.

SM3+SM3 = Hand-push travel

SM3+EM3 = Electric travel

\*\*\* Dimensions with 3m hook-run.

## Maximum reactions of DMT trolley wheels on beam flange for DMK in low headroom execution

DMK size	Max capacity (kg)	DMT trolley type	Ør	i	b	*max R (kg)	Overall dimensions (mm)
1	250	SM3+SM3	80	7	16	44	
		SM3+EM3				45	
2	500	SM3+SM3	80	7	16	80	
		SM3+EM3				82	
3	1000	SM3+SM3	80	7	16	156	
		SM3+EM3				158	
4	2000	SM4+SM4	100	9	19	307	
		SM4+EM4				309	
	4000	SM5-SM5(on request)	125	14	29	/	
		SM5-SM5(on request)				/	

\*Max R calculated with a dynamic coefficient of 1.15 and no M increasing coefficient.

## Characteristics and technical data for DMK chain hoist, climbing execution

Characteristics and technical data for DMK chain hoist, climbing execution

Capacity (kg)	FEM Group	Type	Chain falls	Lifting speed (m/min)		Lifting motor capacity		*Hoist weight (kg)	Chain type	Chain weight per meter (kg/m)
				1 Speed	2 Speed	1 Speed	2 Speed			
125	2m	154C	1	8	/	0.2	/	11	4X12	0.38
250	2m	134C	1	4	/	0.2	/	11	4X12	0.38
	2m	234C	1	8	/	0.4	/	19	5X15	0.58
500	2m	214C	1	4	/	0.4	/	19	5X15	0.58
	2m	334C	1	8	/	0.8	/	32	7X21	1.16
1000	2m	314C	1	4	/	0.8	/	32	7X21	1.16
	2m	434C	1	8	/	1.6	/	49	10X28	2.42
2000	2m	414C	1	4	/	1.6	/	49	10X28	2.42

\* Weight of hoist only, without chain, chain box and controls.

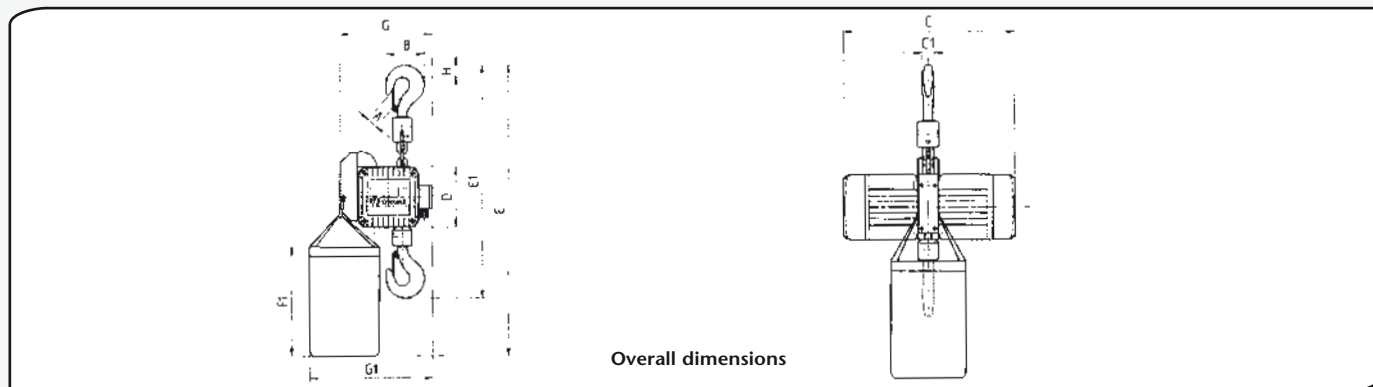

DMK Size	Max capacity (kg)	DMK hoist type DMK	Overall dimensions (mm)											
			A	B	C	C1	D	E	E1	F	F1	G	G1	H
1	125	154C	24	67	355	19	120	710	400	230	360	210	310	19
	250	134C	24	67	355	19	120	710	400	230	360	210	310	19
2	250	234C	28	83	438	22	135	740	465	230	360	225	325	24
	500	214C	28	83	438	22	135	740	465	230	360	225	325	24
3	500	334C	34	103	514	29	160	800	577	230	360	250	350	31
	1000	314C	34	103	514	29	160	800	577	230	360	250	350	31
4	1000	434C	40	127	583	38	200	880	716	230	360	307	410	40
	2000	414C	40	127	583	38	200	880	716	230	360	307	410	40

### Types of tension rods according to min. and max dimensions of beams

Trolley type	Beam type	Group 1	Group 2	Group 3	Group 4	* Minimum radius of internal curvature (mm)
SM2	INP	80÷160	180÷280	300÷380	400	1000
	IPE	80÷140	160÷240	270÷300	330÷500	
	HEA	-	120	140	160÷200	
SM3	INP	120÷240	260÷450	500÷600	-	1300
	IPE	120÷220	240÷360	400÷600	-	
	HEA	-	140÷160	180÷220	-	
SM4	INP	160÷280	300÷450	500÷600	-	1500
	IPE	160÷240	270÷400	450÷600	-	
	HEA	-	160÷180	200÷220	-	
SM5	INP	180÷300	320÷500	550÷600	-	1900
	IPE	180÷240	270÷400	450÷600	-	
	HEA	-	180	200÷240	-	
CM3	INP	140÷240	260÷450	500÷600	-	1300
	IPE	140÷220	240÷360	400÷600	-	
	HEA	-	140÷160	180÷220	-	
CM4	INP	180÷280	300÷450	500÷600	-	1500
	IPE	180÷240	270÷400	450÷600	-	
	HEA	-	180	200÷220	-	
CM5	INP	220÷300	320÷500	550÷600	-	1900
	IPE	220÷240	270÷400	450÷600	-	
	HEA	-	-	240	-	
EM3	INP	120÷240	260÷450	500÷600	-	1300
	IPE	120÷220	240÷360	400÷600	-	
	HEA	-	140÷160	180÷220	-	
EM4	INP	160÷280	300÷450	500÷600	-	1500
	IPE	160÷240	270÷400	450÷600	-	
	HEA	-	160÷180	200÷220	-	
EM5	INP	180÷300	320÷500	550÷600	-	1900
	IPE	180÷240	270÷400	450÷600	-	
	HEA	-	180	200÷240	-	

NOTE For EM electric trolleys with electric travel limit switches, check the R dimension, page 12

\* Available on request: electric trolleys suitable to run on a bend by guide roller kit.

## Electric characteristics of motors, fuses and power cables

Hoist type	Motor type	Poles	Power KW	Power factor cosφ	I <sub>a</sub> 50Hz - (I <sub>n</sub> ) 50Hz			Fuses aM 400V A	Power cable section 400V (ΔU 20V)	
					380V A	400V A	415V A		Ø mm <sup>2</sup>	L m
134C-154C-144C 164C	71C4AS1/1	4	0.2	0.43	3.8(1.4)			4	1.5	≤100
144L-164L	72C4AS1/1	4	0.3	0.43	6.5(2.3)			4	1.5	≤100
152C-152L-142L 162L	72C2AS1/1	2	0.3	0.43	6.6(2.2)			4	1.5	≤100
112D-132D-122D 142D-152D	72K1AS1/1	2/6	0.2/0.06	0.6/0.5	3.3/1.8 (0.8/0.8)			4	1.5	≤100
232C-222C-242C	80C2AS2/2	2	0.4	0.45	6.5(2.5)			4	1.5	≤100
214C-234C-224C	80C4AS2/2	4	0.4	0.48	6.4(2.1)			4	1.5	≤100
222D-232D-242D	81K1AS2/2	2/6	0.4/0.12	0.5/0.5	7.3/2.7(2/1.9)			4	1.5	≤100
222L-232L-242L	81K2AS2/2	2	0.6	0.5	11(3.2)			6	1.5	≤100
224L-234L	81K4AS2/2	4	0.6	0.5	8.4(2.6)			6	1.5	≤100
214D-234D-224D	81K5AS2/2	4/12	0.4/0.12	0.6/0.6	5.2/3(1.6/2)			4	1.5	≤100
212F-222F-232F 242F	81K7AS2/2	2/12	0.4/0.06	0.5/0.6	7/3(2/1.6)			4	1.5	≤100
322C-332C-342C	90C2AS3/2	2	0.8	0.6	14.5(4.8)			6	1.5	≤70
314C-324C-334C	90C4AS3/2	4	0.8	0.46	14(5.2)			6	1.5	≤70
322D-332D-342D	91K1AS3/3	2/6	0.8/0.24	0.7/0.4	8.5/4.3(2.2/2.1)			4	1.5	≤100
322L-332L-342L	91K2AS3/3	2	1.2	0.7	15(3.2)			6	1.5	≤70
324L-334L	91K4AS3/3	4	1.2	0.53	21(5.2)			6	1.5	≤50
314D-324D-334D	91K5AS3/3	4/12	0.8/0.24	0.6/0.5	14.6/4(3.1/2.6)			6	1.5	≤70
312F-322F-332F 342F	91K7AS3/3	2/12	0.8/0.12	0.7/0.5	15/3(2.2/1.7)			4	1.5	≤70
432C-422C-442C	100C2AS4/2	2	1.6	0.7	32(6.2)			10	2.5	≤50
414C-424C-434C	100C4AS4/2	4	1.6	0.6	28(6.5)			10	2.5	≤60
422D-432D-442D	101K1AS4/2	2/6	1.6/0.5	0.85/0.5	28/6(5.5/4)			10	2.5	≤60
422L-432L-442L	101K2AS4/2	2	2.5	0.75	46(9.7)			16	2.5	≤30
424L-434L	101K4AS4/2	4	2.5	0.7	38(6.2)			10	2.5	≤40
414D-434D	101K5AS4/2	4/12	1.6/0.5	0.62/0.4	28/12(5.5/6)			10	2.5	≤60
412F-422F-432F 442F	101K7AS4/2	2/12	1.6/0.25	0.8/0.5	30/12(4/4.1)			10	2.5	≤50
424D-454D	101K5AS4/4	4/12	2/0.65	0.72/0.5	28/8(6.5/5)			10	2.5	≤60
Single-phase					I <sub>a</sub> - (I <sub>n</sub> ) 230V - 50Hz			230V	Ø mm <sup>2</sup> 230V (ΔU 11.5V) L m	
132M-112M	72K2AM1/1	2	0.2	0.9	9.6	(3.2)		6	1.5	≤ 60
234M-214M	81K4AM2/1	4	0.4	0.9	11.3	(5.2)		10	1.5	≤ 50
334M-314M	91K4AM3/2	4	0.8	0.9	32	(12)		20	2.5	≤ 30

Trolley type	Motor type	Poles	Power kw	Power factor cosφ	I <sub>a</sub> 50Hz - (I <sub>n</sub> ) 50Hz 400V A
EM3-EM4	71C4TV1/1	4	0.25	0.43	3.8(1.4)
EM3-EM4	71C8TS1/1	8	0.12	0.53	2.5(1.3)
EM3-EM4	72K6TS1/1	6	0.18	0.5	3(1.7)
EM3-EM4-EM5	81C5AD2/1	4/12	0.25/0.08	0.54/0.7	4.5/1.8(1.4/1.2)
EM5	80C4TV2/1	4	0.37	0.7	4.4(1.7)
EM5	80C8TS2/1	8	0.17	0.5	2.6(1.6)
EM5	80C6TS2/1	6	0.25	0.5	3.8(1.2)
Single-phase					I <sub>a</sub> - (I <sub>n</sub> ) 230V 50Hz A
EM3	71C8TM1/1	8	0.1	0.8	8.6 (3.2)

since 1930



09.09 - ARTESTAMPA, Galliate Lombardo (Va)

**DONATI SOLLEVAMENTI S.R.L.**

Via Roma, 55 - 21020 Daverio (Varese) - Italy - tel. +39 0332 942.611 - fax +39 0332 949.597  
E-mail: [info@donati-europe.com](mailto:info@donati-europe.com) - [www.donati-europe.com](http://www.donati-europe.com)

**DONATI U.K.**

Unit 40 - Farriers Way Ind. Est. - NETHERTON - LIVERPOOL L30 4XL  
tel. +44 (0)151 530 1139 - fax +44 (0)151 525 6613 - E-mail: [sales@donati.co.uk](mailto:sales@donati.co.uk)



ISO 9001  
Cert. n. 0114

MAN02CG03